

APPLY LUBRICANT TO ALL SEALS PRIOR TO INSTALLATION. DO NOT USE SILICONE TYPE LUBRICANTS. FOR PROPER ARM MOUNTING SEE IS1505.

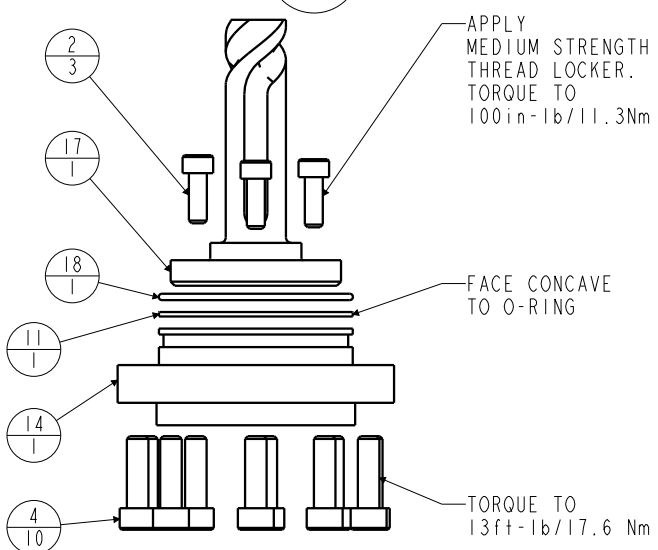
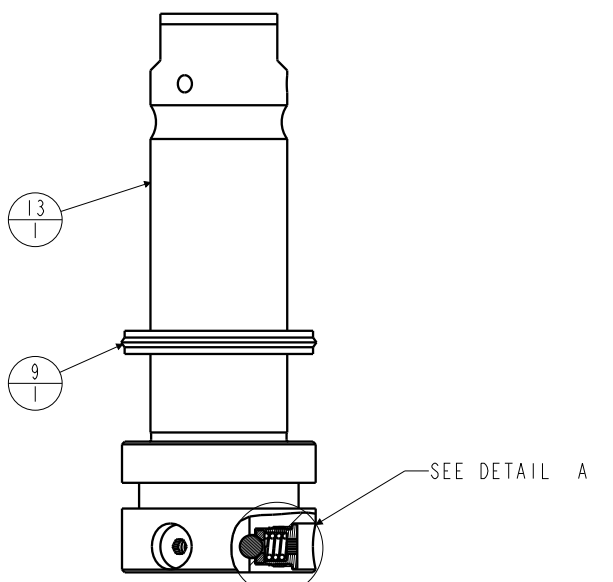
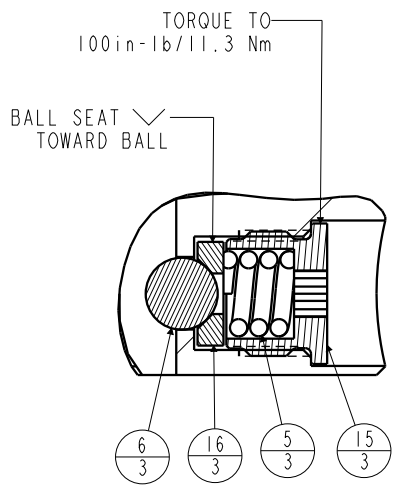

N/A	N/A	IS1505	INSTRUCTION SHEET, ARM INSTALLATION		
N/A	N/A	6V711036	SEAL KIT, FKM		
N/A	N/A	60711036	SEAL KIT, STANDARD		
19	1	39V11051	WIPER,PRESS-IN, (1-1/2)	X	X
18	1	39H51002	O-RING, (-033)	X	39V51002
17	1	81592126	CAM,SC,LP,7500/33KN,RH,LS,TC		
16	3	81532108	SEAT, BALL, SC, LP, TC		
15	3	81532107	RETAINER, SC, LP, TC		
14	1	81532105	CAP, END, SC, LP, 33kn/7500		
13	1	81512112	PLUNGER,SC,LP,7500/33KN,DA,LS,TC		
12	2	43068006	PLUG, 1/4 BSPP MALE		
11	1	39054017	BU RING, (-033)	X	39054023
10	1	39054016	BU RING,(1.5x.125x.063)	X	X
9	1	39052030	SEAL,CROWN,1-3/4x2-1/8x1/4	X	39V52030
8	2	39050042	O-RING, (-011)	X	39051025
7	1	39011075	SEAL, LL, (1-1/2 X 1/8 X 1/8 1-3/4)	X	39V11075
6	3	23650004	BALL,TUNGSTEN-CARBIDE.250		
5	3	23350066	SPRING, COMPRESSION		
4	10	21500304	SHCS, M6 X 1.0-66 X 20MM		
3	2	21500200	WASHER		
2	3	21500031	SHCS, M5 x 0.8 x 14, ALY		
1	2	21500019	SCREW, CAP, BTNH, M3 X 6, ALY		
No.	QTY	PART No.	DESCRIPTION	Std. Seal Kit	FKM Seal Kit

<h3>PARTS LIST</h3>	<p>VEKTEK, INC. 1334 E. SIXTH AVE. P.O. BOX 625 EMPORIA, KS. 66801 U.S.A.</p>
<p>PARTS LIST, ASSY,SC,LP,TC,TF,33KN,DA,RH,LS</p>	<p>SIZE A MPL7157</p>
<p>FORM FEG035_PL_ASIZE, REV. B</p>	<p>REV C</p>

C	5762	RELEASE	JDW	07/15/25
REV	IN ACCORDANCE WITH ECN	EFFECTIVE DATE	REVISED BY	DATE
DRW BY:	JDW	DRAWING STATUS: Released		
DATE:	6-7-11	PRODUCTION APPROVED FOR RELEASED STATUS ONLY		

